

# Fitness Entertainment Solutions

## 2.4 GHz Receiver Part #ARG-2.4R Manual and User Guide



User Guide Part #ARG-OM-32 – Rev C  
Updated: 1/5/2017

**Unpacking the box** – Inside the box of your new transmitter you will find the following items.

1. The 2.4 GHz Radio receiver housing and headphone module
2. The user manual(ARG-OM003)
3. Three 11" x 3/16" black cable ties (ARG-ZT001)

**Optional Accessories**

1. Short coiled C-SAFE cable (ARG-CA010)
2. Long coiled C-SAFE cable (ARG-CA009)
3. Removable headphone jack module in 10 pack (ARG-HJ2-010)
4. 12VDC C-SAFE Power supply (ARG-PS009)
5. Programming Module (ARG-PM003)

**CONTROL FUNCTIONS:**

The buttons on the receiver perform the functions as detailed below:

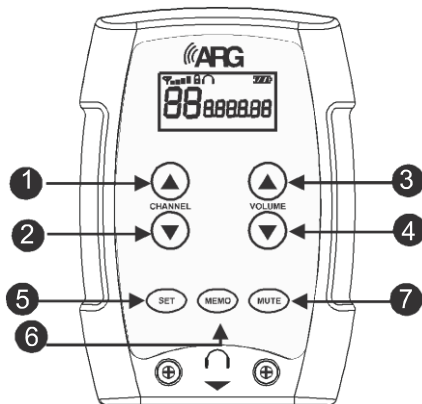

1. CHANNEL UP Button
3. VOLUME UP Button
5. SET Button
7. MUTE Button
9. Auto Power and 3.5mm Audio Jack

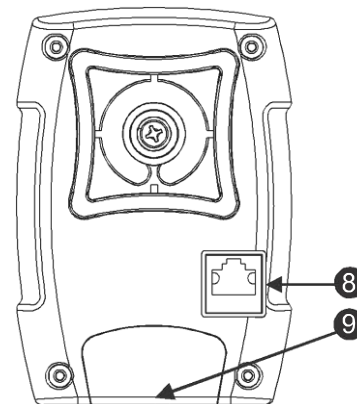

2. CHANNEL DOWN Button
4. VOLUE DOWN Button
6. MEMO Button
8. C-SAFE Port

**MOUNTING INSTRUCTIONS:**

The ARG 2.4GHz Receiver is a universal unit designed to be compatible with most makes and models of cardio equipment. To mount the Receiver:

1. Determine the appropriate location to mount the receiver to the cardio equipment. Take note the range of motion of the components of machine and make sure the placement of the receiver and its cabling will not interfere with operation of the machine or any safety features.
2. Slide the cable ties through the appropriate holes in the mounting cleat on the underside of the receiver. (Top to bottom if you are mounting it to a horizontal bar or side to side if you are mounting to a vertical bar.)
3. Wrap and thread the cable ties around the bar on the cardio machine at the pre-determined location. Pull the ties tightly around the bar so the receiver does not move or rotate. Be careful not to over-tighten the ties to avoid cracking the mounting cleat or receiver case. Trim off the excess ends of the cable ties.
4. Connect the power cable to the receiver. The receiver can be powered by either a C-SAFE power outlet on the cardio machine or an A/C power converter that is plugged into the wall/floor. (Power adapters and cables are not included and must be ordered separately.) If you are using a C-SAFE connection: connect one end of the Cat-5 cable to the C-SAFE port on the cardio machine. (Check with the equipment manufacturer to make sure the machine has this feature and for location of the outlet.) The other end of the cable connects to the RJ45 receptacle on the back of the receiver. If you are using an A/C power supply: locate a standard 110V outlet and plug the 12V A/C adapter side into the outlet and the RJ45 plug into the receptacle on the back of the receiver. Make sure to route the cord for either option appropriately to avoid interference with any of the functions or safety features of the cardio machine.

Note: Once mounted, the receiver can be rotated by lifting the main unit away from the cardio equipment and rotating it to the desired angle. It will lock back down on its own. Verify that the unit is locked correctly by gently turning the unit to the right or left.

## **OPERATING INSTRUCTIONS:**

### **POWER ON/OFF:**

The receiver is powered on and off by inserting the headphone plug into the headphone jack. When you plug the headphones in, the receiver will turn on. When you unplug the headphones, the receiver will turn off after several seconds.

### **SELECTING THE LISTENING CHANNEL:**

The receiver will show the channel number it is tuned to on the left side of the LED display. Select the channel number for the receiver to “tune-to” by pressing the “CHANNEL UP” or “CHANNEL DOWN” button on the front of the receiver. The “CHANNEL UP” button will make the channel step up by one. The “CHANNEL DOWN” button will make the channel step down by one. There are a total of 14 channels to choose from.

### **PROGRAMMING THE RECEIVER:**

The receiver has the option to hide unused channels where there is no transmitter broadcasting. To do so the unit must be in the programming mode. To enter the programming mode press and hold the SET and MEMO buttons for seven seconds till the lock icon disappears from the LCD. Use the CHANNEL UP and CHANNEL DOWN buttons to scroll through the 14 channels of the receiver. When a channel that you want to hide is selected, press the MEMO button till the LCD no longer displays “Memory” on the bottom right. Press the MEMO button again to recover it. To exit the programming mode press and hold the SET and MEMO buttons for seven seconds till the lock icon reappears on the LCD.

### **ADJUSTING THE LISTENING VOLUME:**

Press the “VOLUME UP” button or “VOLUME DOWN” button to raise or lower the volume level. When the receiver is powered on, the volume will default to 07. The volume can be set between the range 0 and 16. Pressing the “MUTE” button will mute the sound and the volume number will flash in the display. Press the “MUTE” button a second time to restore.

### **RESETTING THE RECEIVER:**

The receiver is equipped with built-in, self-protection circuitry that will activate when receiving a variety of electrical or environmental circumstances. This may cause the unit to lock-up or behave in an undesired fashion. If this occurs, reset the receiver by disconnecting it from the power source for one minute. This will restart the software and should return the unit to normal operation. If problems persist, please contact your dealer or ARG for further assistance.

## HEADPHONE JACK REPLACEMENT:

Because it is subject to heavy use, it is normal for the contacts in the headphone jack assembly to wear out over time. The 2.4Ghz receiver is equipped with a replaceable headphone jack module to address this wear without replacing the entire unit. Under ideal conditions, the headphone jack is rated to last roughly 6,000 plug insertions and removals (cycles). After 6,000 cycles, an icon that looks like headphones will flash in the display to alert that the headphone jack should be replaced. Every time the receiver is powered-up, the display will flash the number cycles the module has used under the letters "2.4G". The headphone jack module can, in most cases, be changed without removing the receiver unit from the cardio machine.

1. To remove the worn jack, locate the two Philips screws on the front bottom of the unit. They will be on either side of the headphone/power logo located under the foam inserts.
2. Remove the black foam inserts.
3. Remove these two screws and set the screws to the side.
4. The headphone jack module will drop out of the unit.
5. Replace the headphone jack module.
6. While holding the module in place insert and tighten the two screws.
7. Plug in a set of headphones to power on the receiver
8. Press the SET and MEMO buttons for seven seconds to enter the programming mode
9. Press the MEMO and MUTE buttons for seven seconds till the flashing headphone icon disappears.
10. Press the SET and MEMO buttons for seven seconds to return to user mode.



## SETTING COPY:

New ARG receivers have the ability to copy settings from one unit over to another unit. This greatly speeds up programming multiple units as it takes approximately one minute to copy all settings. To copy from one unit to another the optional copy module is required. (ARG-PM03).

1. Program one receiver manually. This receiver will be referred to as the master receiver. The other receivers will be referred to as slave receivers.
2. Plug the copy module power adaptor into power and connect two C-SAFE/CAT-5 cables to the copy module.



3. Remove the headphone jack module from the master receiver and slave receiver by removing the two set screws in the front of the unit (Note: refer to headphone jack replacement to remove the jack).
4. Connect the other end of one of the C-SAFE cables from step 2 to the master receiver and the second C-SAFE cable to the slave receiver.



5. On the master receiver locate the small button in the headphone jack compartment.
6. Press this button once. ARG Audio recommends using a paperclip for this.



7. At this point the backlight on both the master and slave receiver will turn on. This means that the copying has started. **Do not disconnect either receiver from the copy assembly until copying has completed as this could cause damage to the receivers.**
8. Copying will take approximately one minute. After copying has ended both backlights will turn off.
9. Disconnect both receivers and test the slave receiver to see if programming has copied.
10. Repeat steps 4 through 9 for each additional receiver to be programmed.
11. After programming all receivers has been completed, replace the headphone jack module, tighten the two screws and insert the black foam spacer.





## Warranty Statement

Audio Resource Group, Inc. (ARG) develops, designs and distributes only high quality products that will provide users with many years of trouble-free service. Some of the products we distribute are sold exclusively by ARG. The following Warranty Statement defines the warranty periods for each product line and model of equipment distributed by Audio Resource Group, Inc.

### **Talk and Listen™ Systems**

ARG warrants the following transmitters and receivers (TX72BP, TX72M, TX900BP, TX900HH, TX900M, RX72BPS, RX72BPM, RX72BP, RX72M, RX900BP, RX900M) to be free from defects in workmanship and material under normal use and conditions for five years from date of purchase.

ARG warrants the following charging systems (CHGR12, CHR24) to be free from defects in workmanship and material under normal use and conditions for two years from date of purchase. Rechargeable batteries in the TX72M, TX900M, RX72M, and RX900M are warranted for 2 years. Power Supplies are warranted for 90 days.

All other parts and accessories are warranted for 90 days from date of purchase.

### **VoiceAmp® Portable Amplifiers**

ARG warrants the following VoiceAmp portable amplifiers (VA20WB, VA20T, and VA30SE) to be free from defects in workmanship and material under normal use and conditions for five years from date of purchase. Batteries for these listed products are warranted for two years from date of purchase.

All other parts and accessories are warranted for 90 days from date of purchase.

### **Fitness and Cardio Entertainment Products**

ARG warrants the following transmitters (ARG-CV-FMT, ARG-CV-900T, ARG-900AT, and ARG-CV-2.4T) to be free from defects in workmanship and material under normal use and conditions for four years from date of purchase.

ARG warrants the following receivers (ARG-CV-FMR, ARG-CV-900R, ARG-900AR, ARG-CV-2.4R and ARG-2.4R) to be free from defects in workmanship and material under normal use and conditions for two years from date of purchase.

ARG warrants the following personal viewing screens and accessories (ARG-PVS15LED, ARG-PVS19LED, ARG-PVSC) to be free from defects in workmanship and material under normal use and conditions for two years from date of purchase.

All other parts and accessories are warranted for 90 days from date of purchase.

The Warranty is only available to the original end purchaser of the product and cannot be transferred. Warranty is void if damage occurred because of deliberate or accidental physical damage, neglect, misuse or if the product has been repaired or modified by anyone other than a factory authorized service technician. Warranty does not include normal wear and tear on the product or any other physical damage unless the damage was the result of a manufacturing defect. ARG is not liable for consequential damages due to any failure of equipment to perform as intended.

The above stated warranty is exclusive and replaces all other warranties express or implied, including those of merchantability and fitness for a particular purpose. ARG will not be held liable for any other damages or loss including incidental or consequential damages and loss of profit or revenues from whatever cause including breach of warranty or negligence.

The terms of the warranty are governed by the laws of the state of North Dakota. This warranty, prices, and the specifications of products are subject to change without notice.

Revised 1/4/2017

# Repairs and Returns

If you are experiencing difficulty with your system please review the Troubleshooting section of your manuals and user guides for tips and techniques to correct your issues. If you continue to experience problems with your equipment, please call Audio Resource Group, Inc. (ARG) toll-free Customer Service Assistance number at (888) 468-4552.

If it is necessary to return your system for service, you must first be issued a Return Authorization Number (RMA) by our Customer Service Technician prior to sending the system to ARG. All returns must be prepaid by the sender (no freight collect shipments will be accepted). Make sure to clearly mark the RMA number on the outside of the package and ship to:

**Ship To:**

Audio Resource Group, Inc.  
Attn: Repair Department  
405 Main Ave W Unit 3A  
West Fargo, ND 58078

**Out-of-Warranty Repairs:**

We can service/repair most Out-of-Warranty products. These repairs will be charged in accordance with our Flat Rate Repair Schedule. Please contact your sales representative or customer service for a repair quotation under our Flat Rate Repair Schedule.

**Repair Quotes:**

In some cases, if your product is not listed on the Flat Rate Repair Schedule, we can provide you with a repair price based on an individual repair cost estimate.

**Warranty Repairs:**

The ARG warranty period begins from date of purchase. Warranty is only available to the original end purchaser of the product and cannot be transferred. We will, at our option, repair or replace any part or product found to be defective in workmanship or material under normal use and condition. Warranty is void if damage occurred because of deliberate or accidental physical damage, neglect, misuse or if the product has been repaired or modified by anyone other than a factory authorized service technician. Warranty does not include normal wear and tear on the product or any other physical damage unless the damage was the result of a manufacturing defect.

**Returns for Credit:**

Items returned for credit, in "like new" condition (unopened, or original packaging intact), will be issued a full credit (minus applicable shipping charges). Items returned for credit after 30 days are subject to a restocking fee. We are unable to issue credit for any items after 90 days from the date of purchase. Additional fees or partial credit may occur due to missing or damaged items.

**Ship To:**

Audio Resource Group, Inc.  
405 Main Ave W Unit 3A  
West Fargo, ND 58078  
Phone: (888) 468-4552 Fax: (888) 373-4819  
repairs@argaudio.com

ARG Repairs and Return policies, programs, and pricing are subject to change without notice.